

One Point Perspective

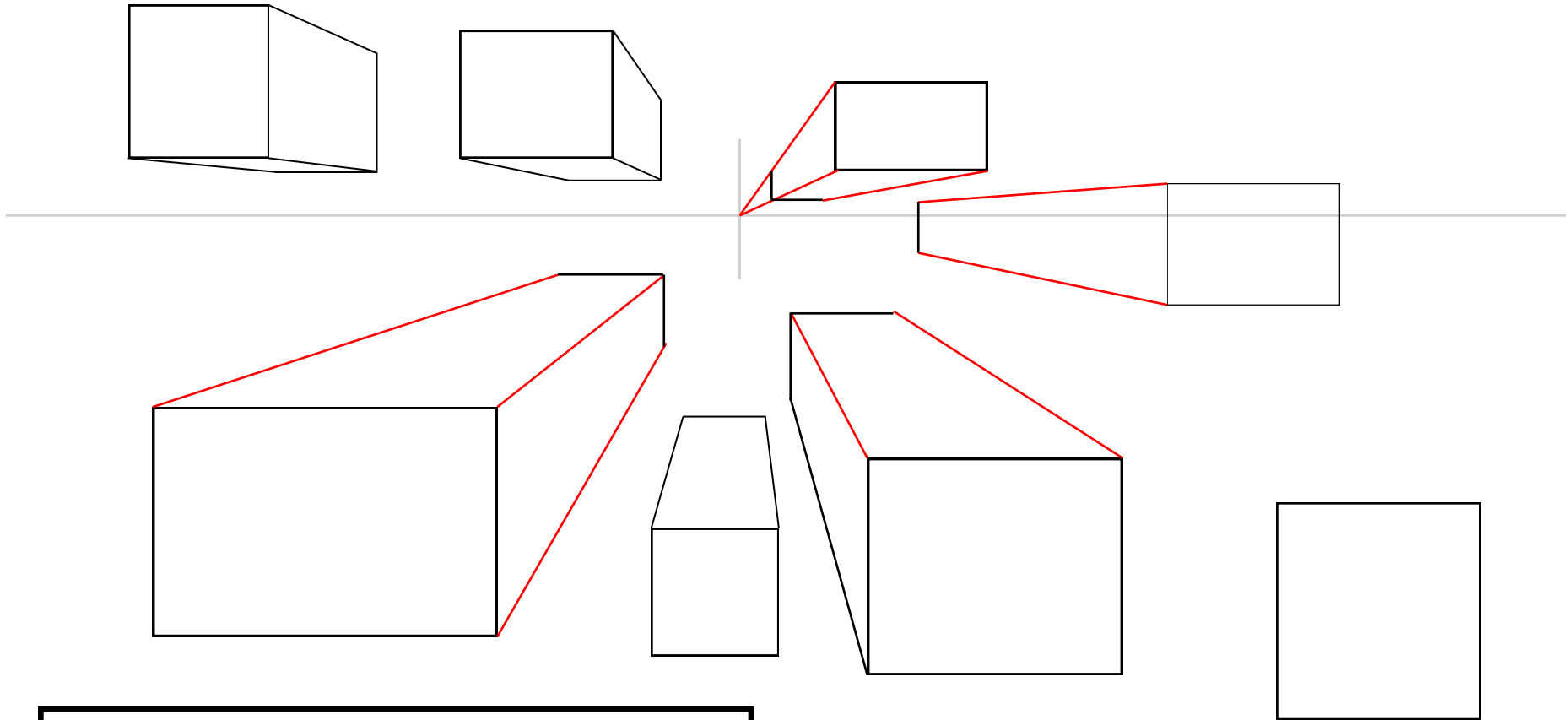

Draw line all the way to the VP and then hold down shift to retain the placement and shorten the line.

Diana vanderSon

Two Point Perspective

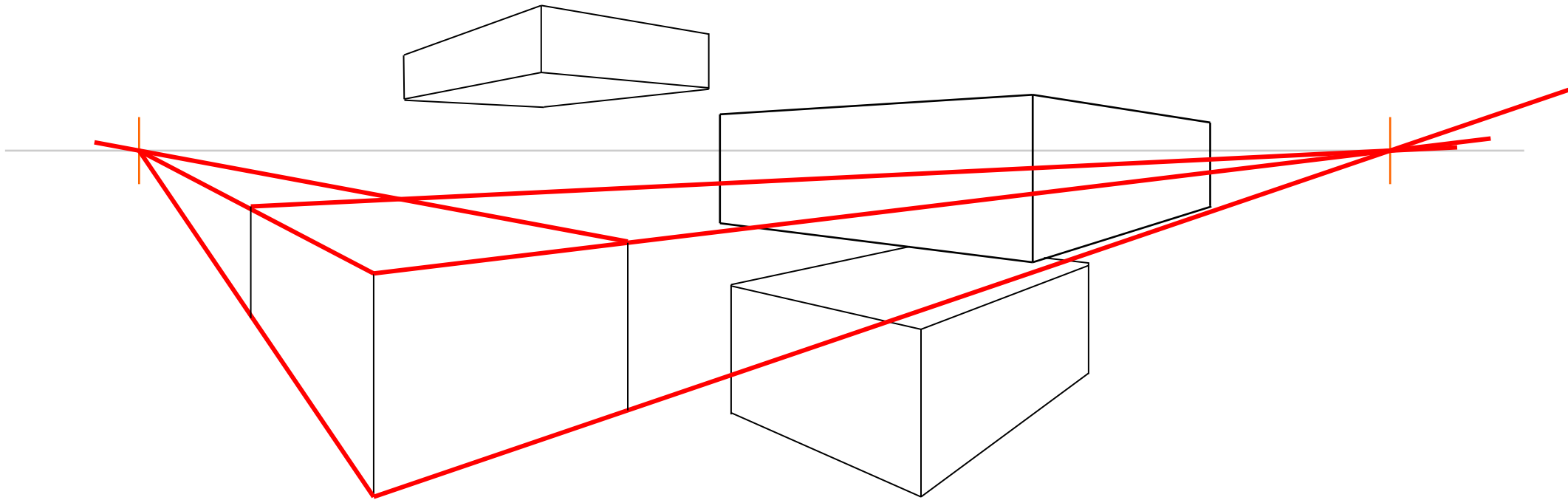

All done with lines!!!!

Diana vanderSon

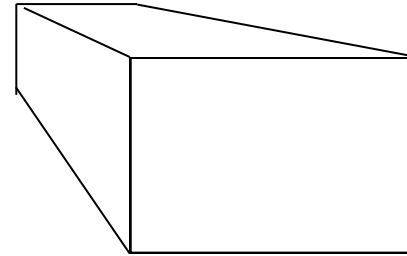
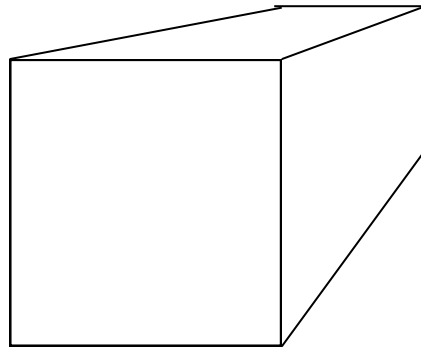
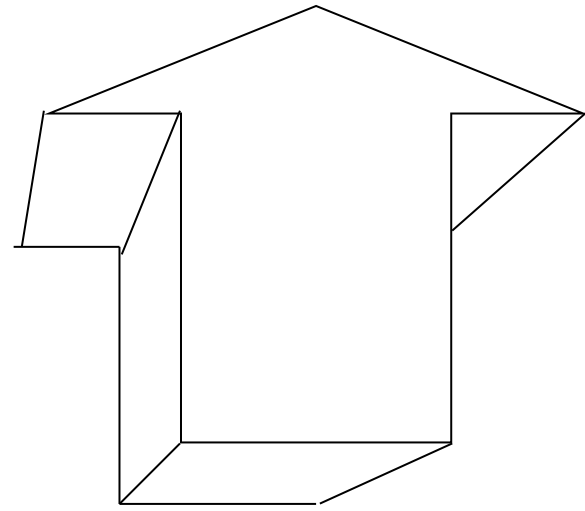
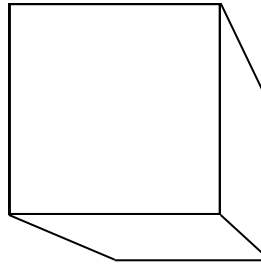
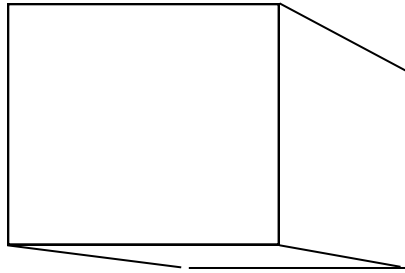

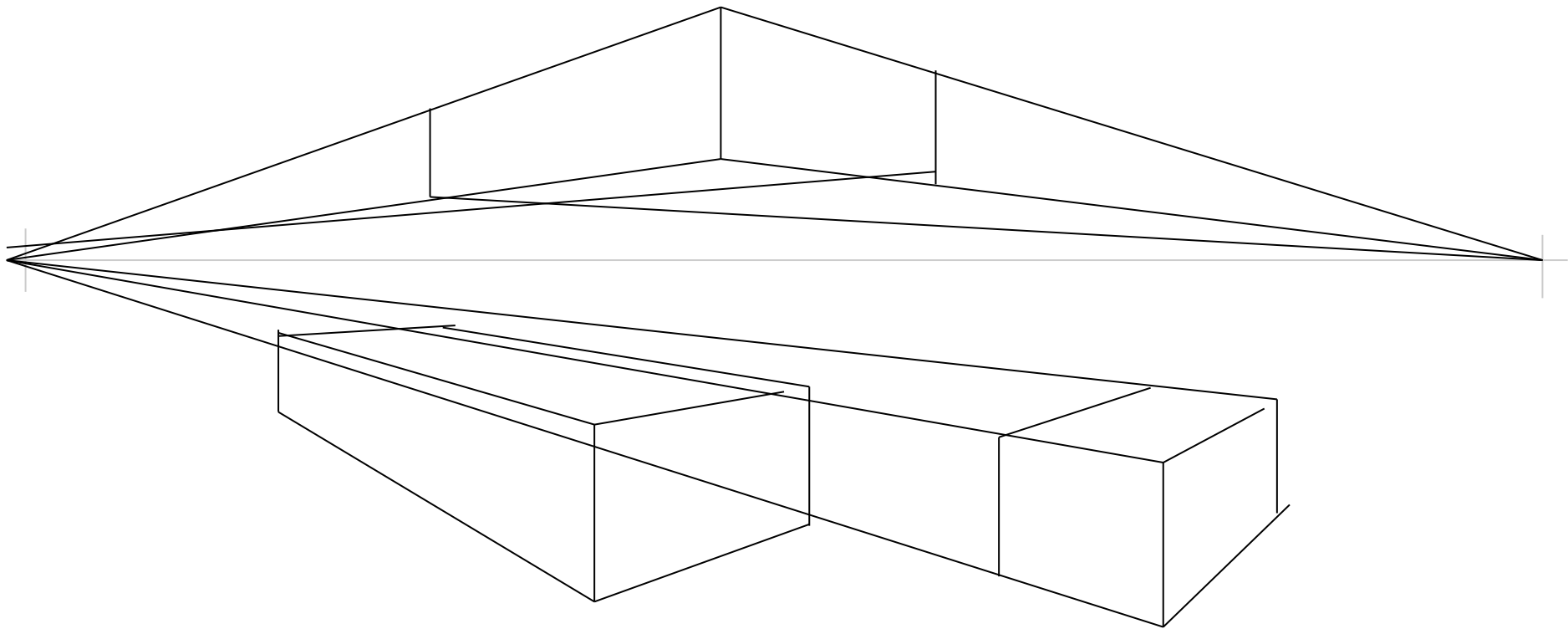

One point perspective - City Street

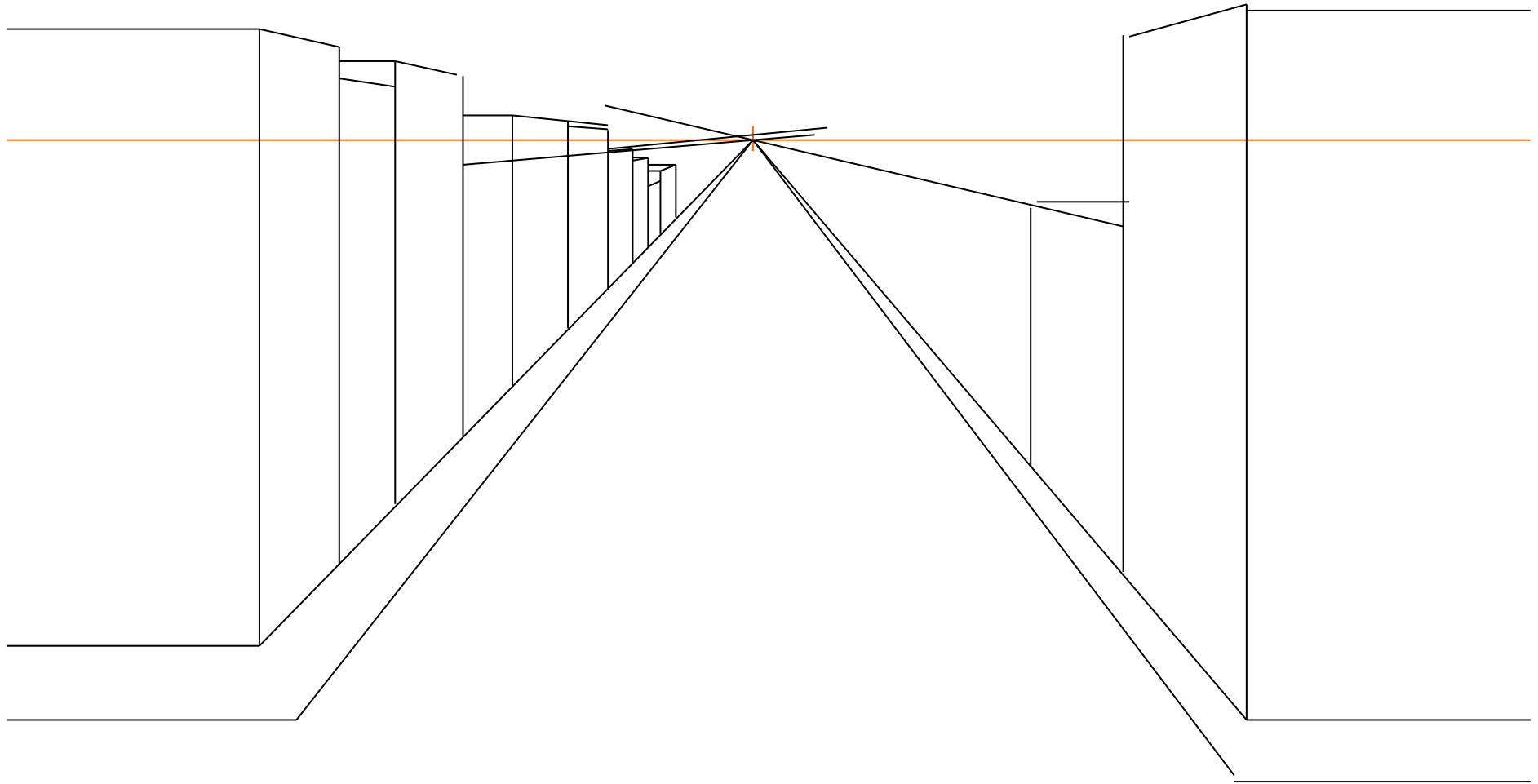

Two point perspective - City Scape.

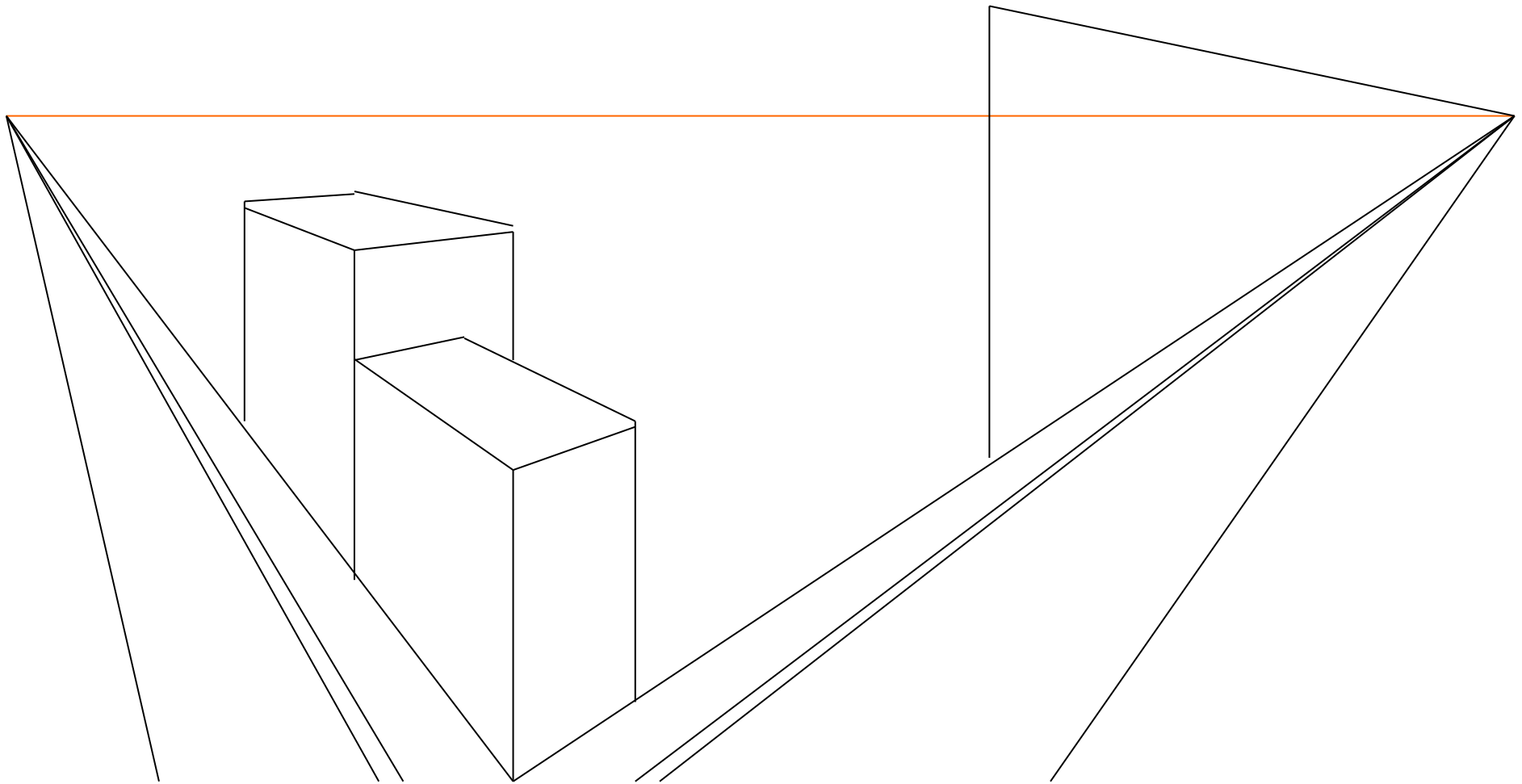

Two point perspective - city

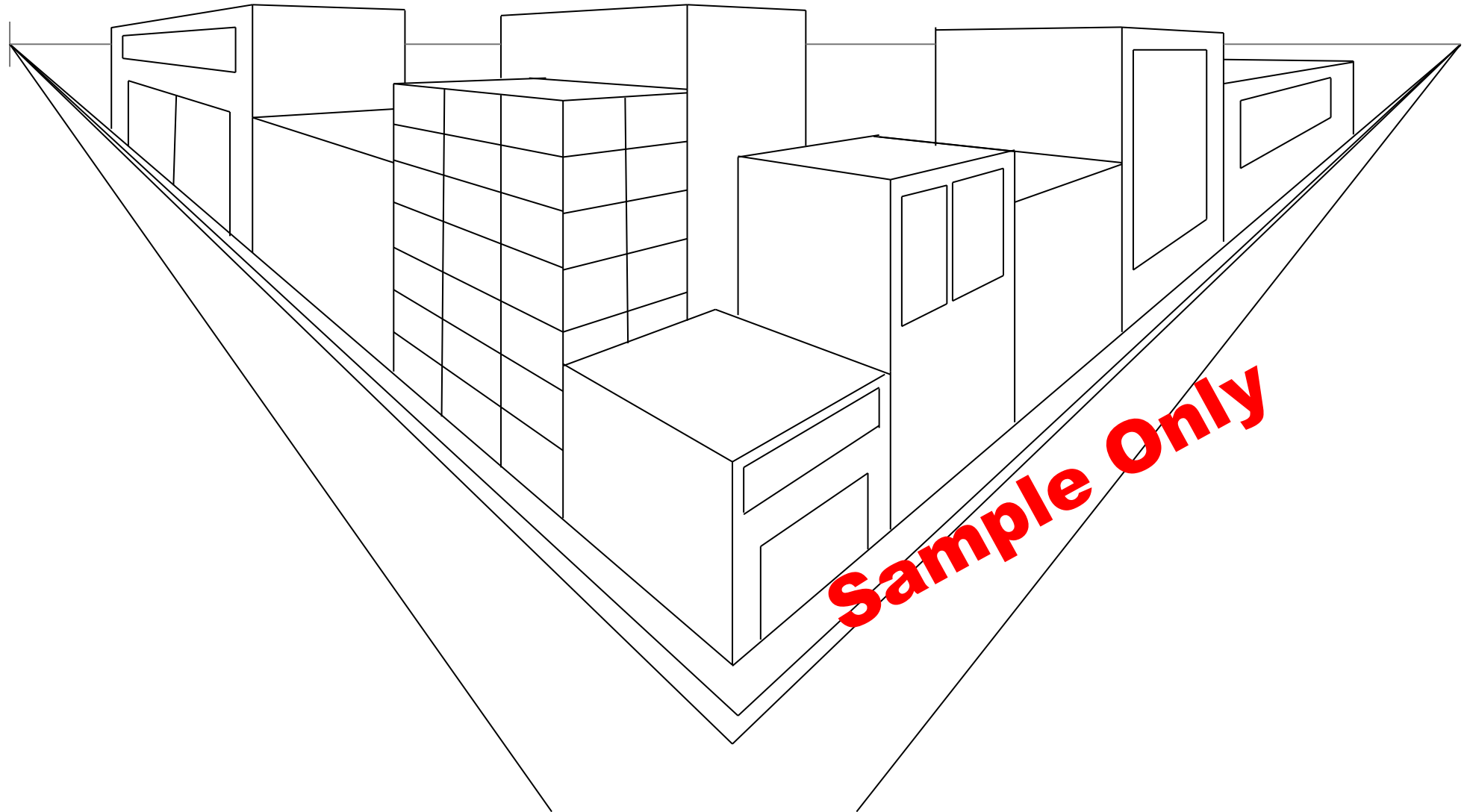

Sample Only

One point perspective — city street

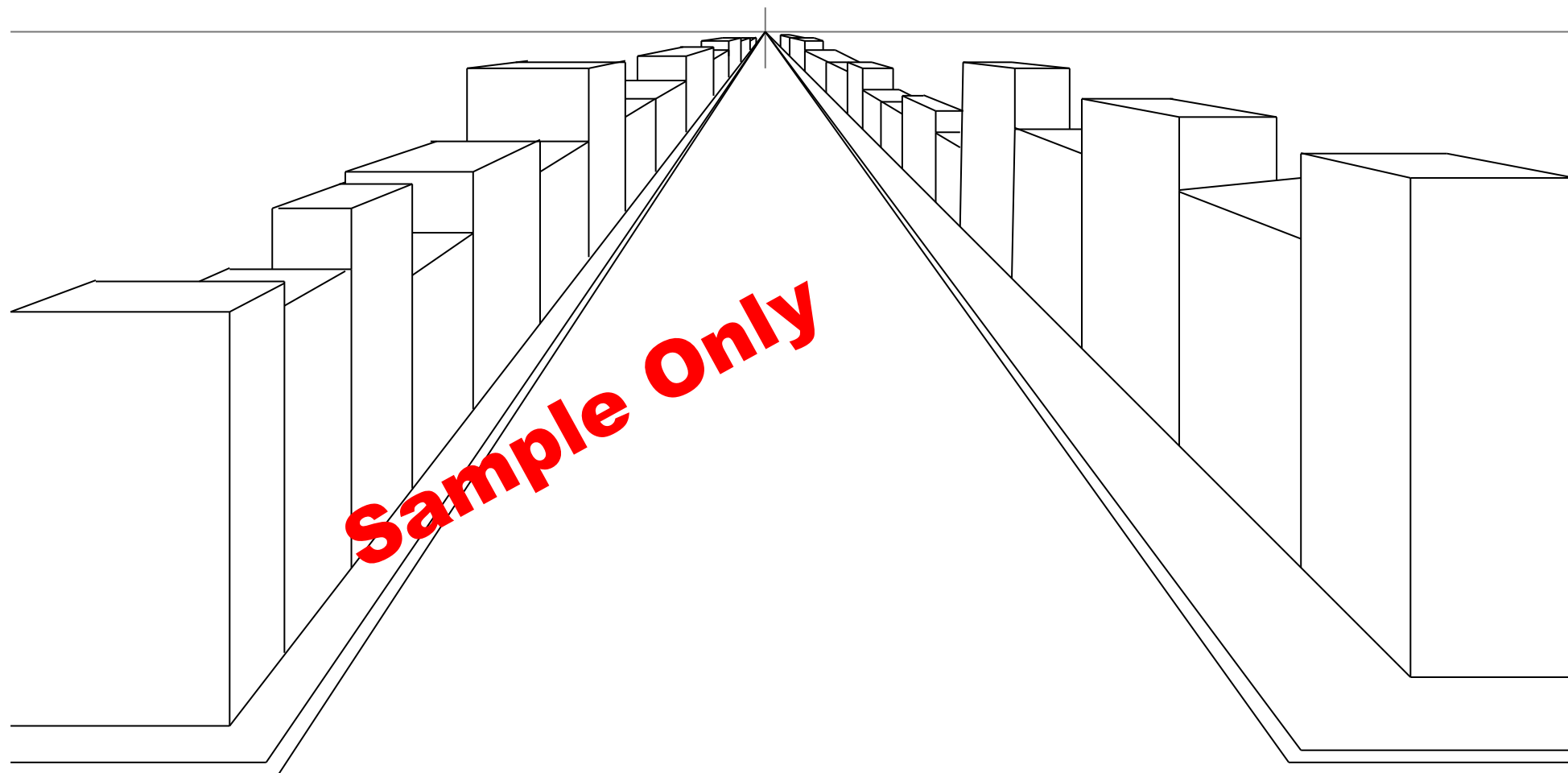



Sample Only

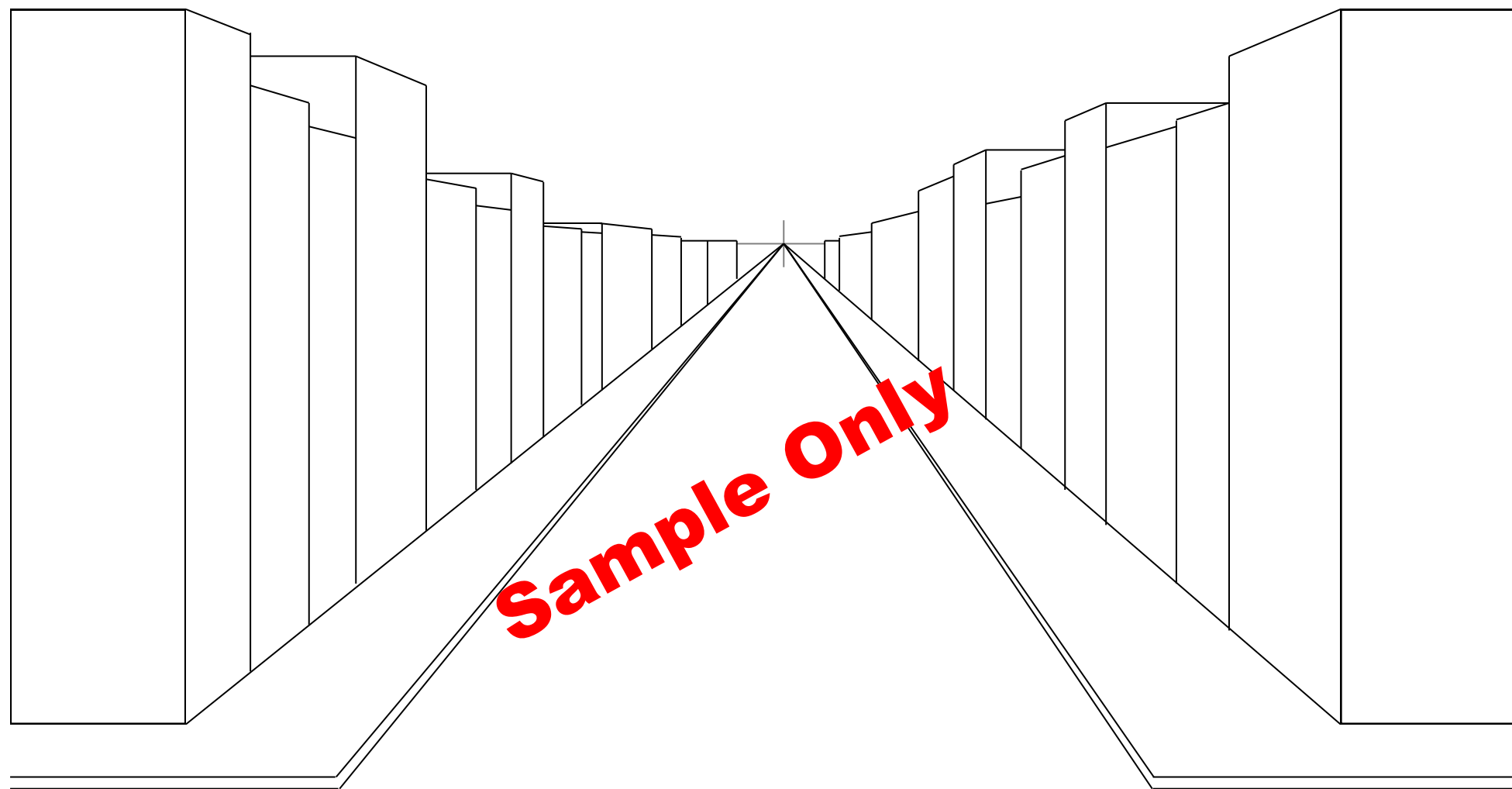

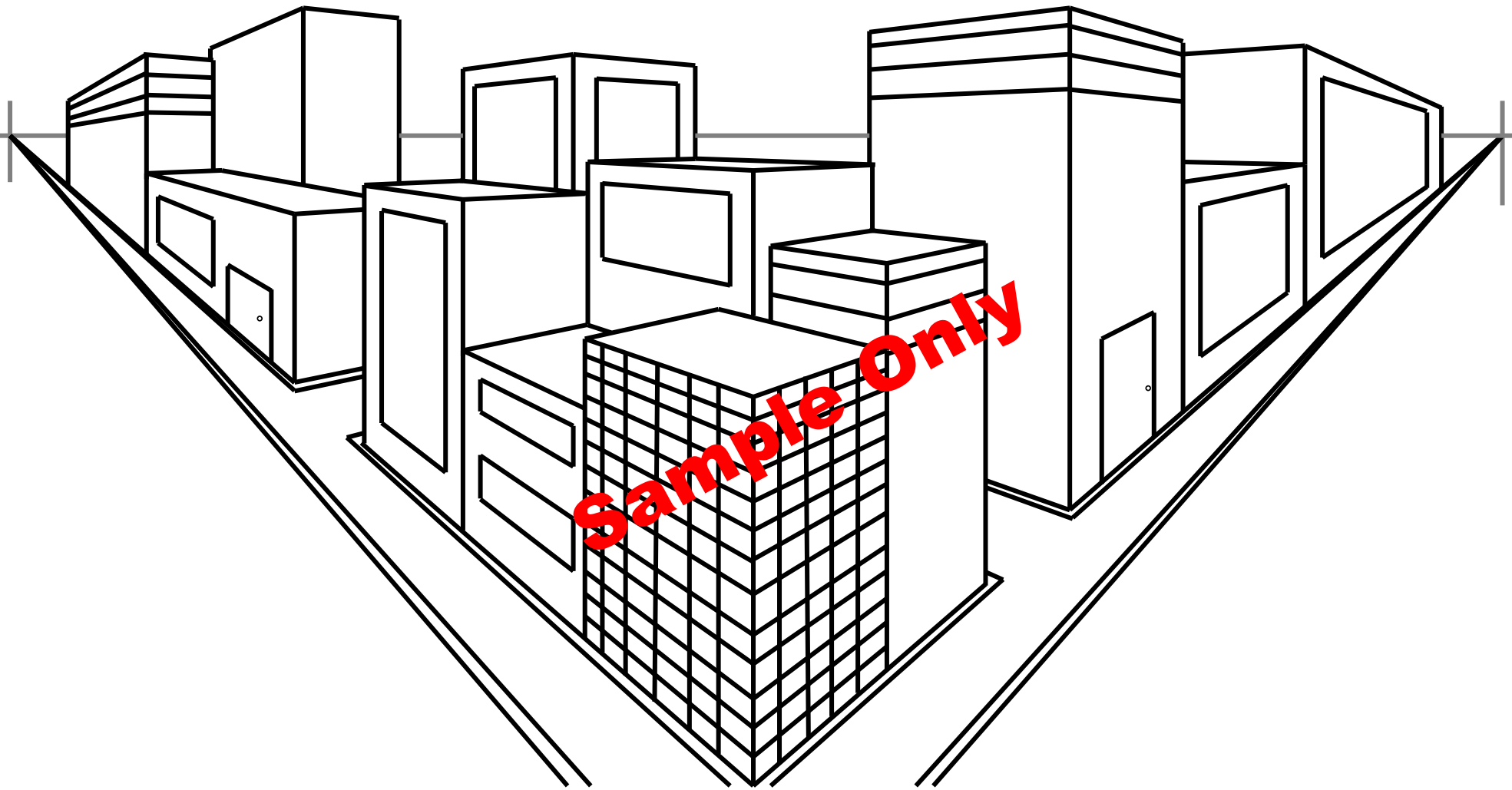

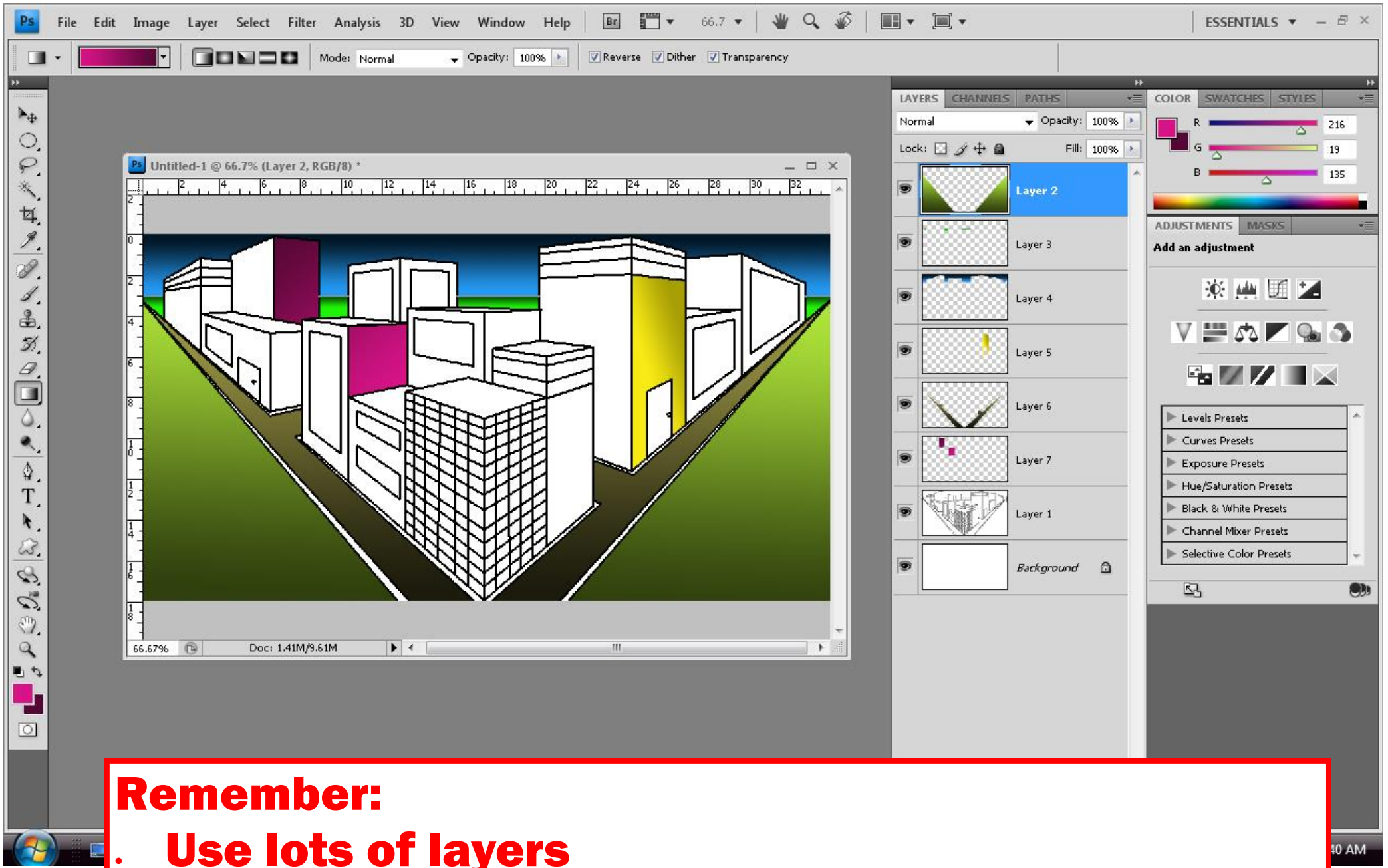

Remember:

- Use lots of layers
- Use gradient fill—dark close, light further away.